

CASE 988

**Max Capacity Contours of Radius(m) Plots 2.1m Dipper
Gradient 1 in -25 Heights 4m to 1m Lift BP**

Unlocked Rail Cant -150mm

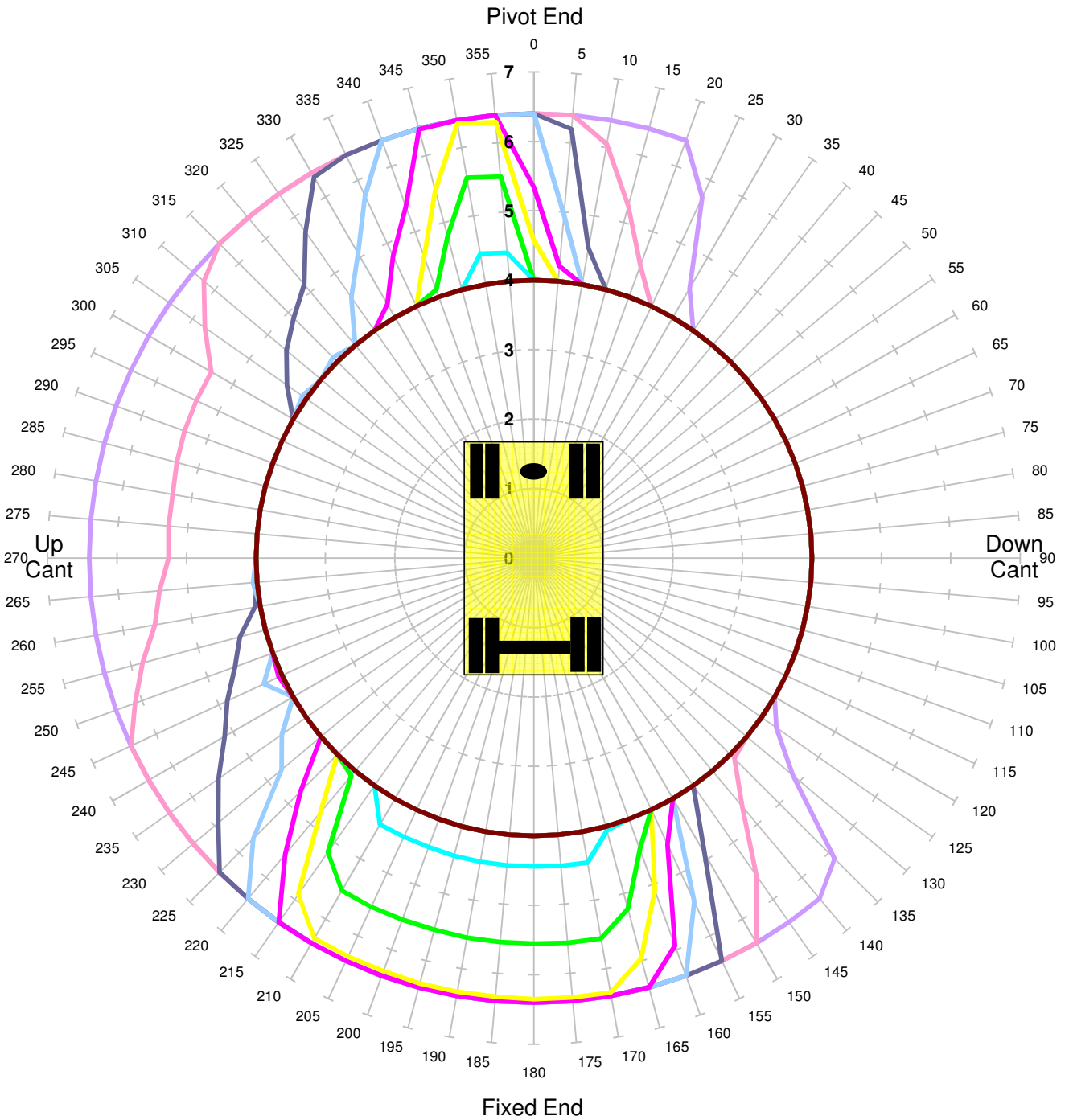

Units in Tonnes



MACHINE & MODEL: SERIAL No: EQUIPMENT: COMMENT:	CASE 988 231287 Plant Number 84 4.30m + 2.10m	REFERENCE: DATE OF CHART: SAFETY FACTOR:	CC587 26-Jan-2016 67.0%
--	---	---	-------------------------------

CASE 988

**Max Capacity Contours of Radius(m) Plots 2.1m Dipper
Gradient 1 in -25 Heights 4m to 1m Lift BP
Unlocked Rail Cant -50mm**

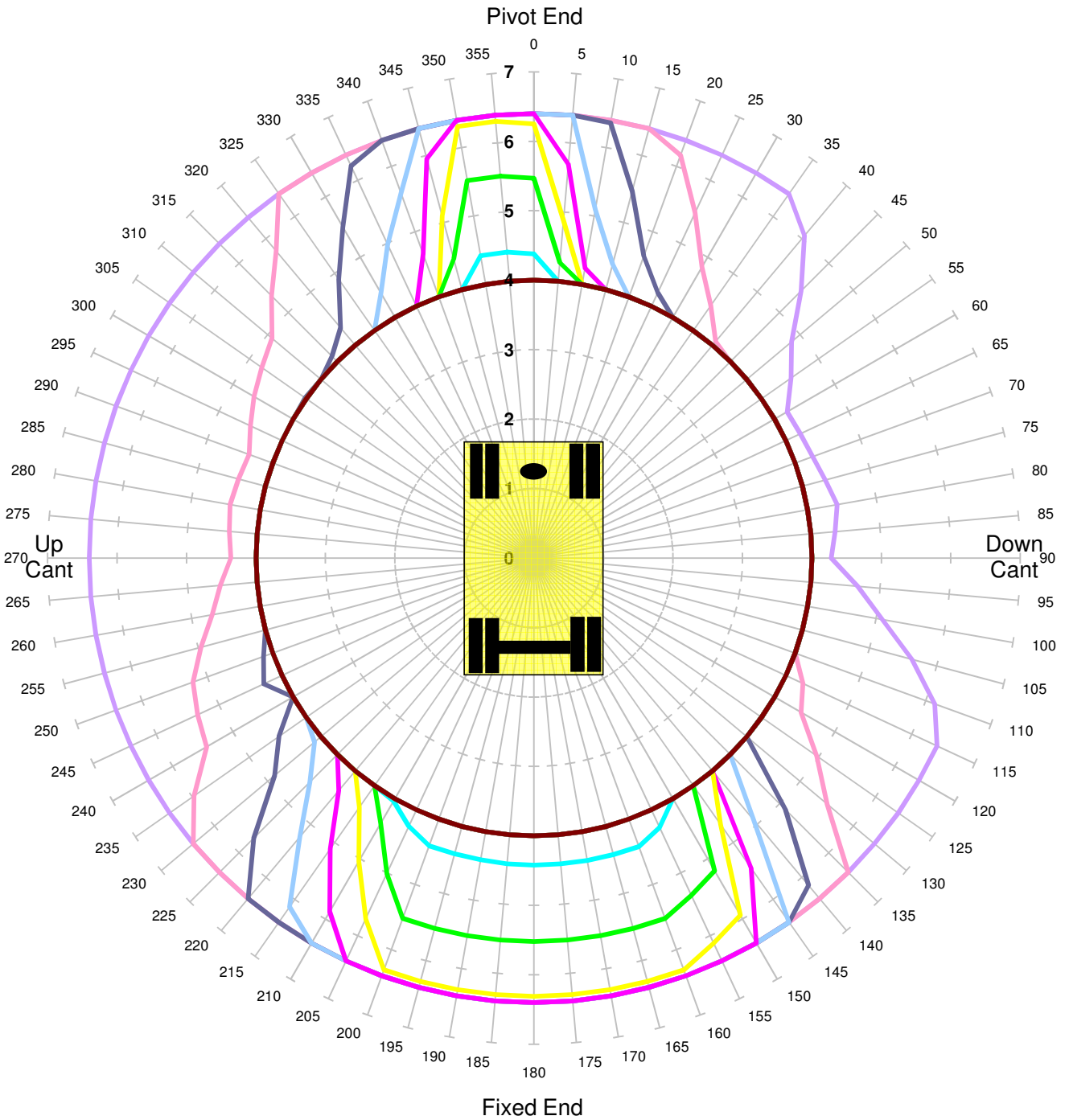

Units in Tonnes



MACHINE & MODEL:	CASE 988	REFERENCE:	CC587
SERIAL No:	231287 Plant Number 84	DATE OF CHART:	26-Jan-2016
EQUIPMENT:	4.30m + 2.10m	SAFETY FACTOR:	67.0%
COMMENT:			

CASE 988

**Max Capacity Contours of Radius(m) Plots 2.1m Dipper
Gradient 1 in -25 Heights 4m to 1m Lift BP**

Unlocked Rail Cant 50mm

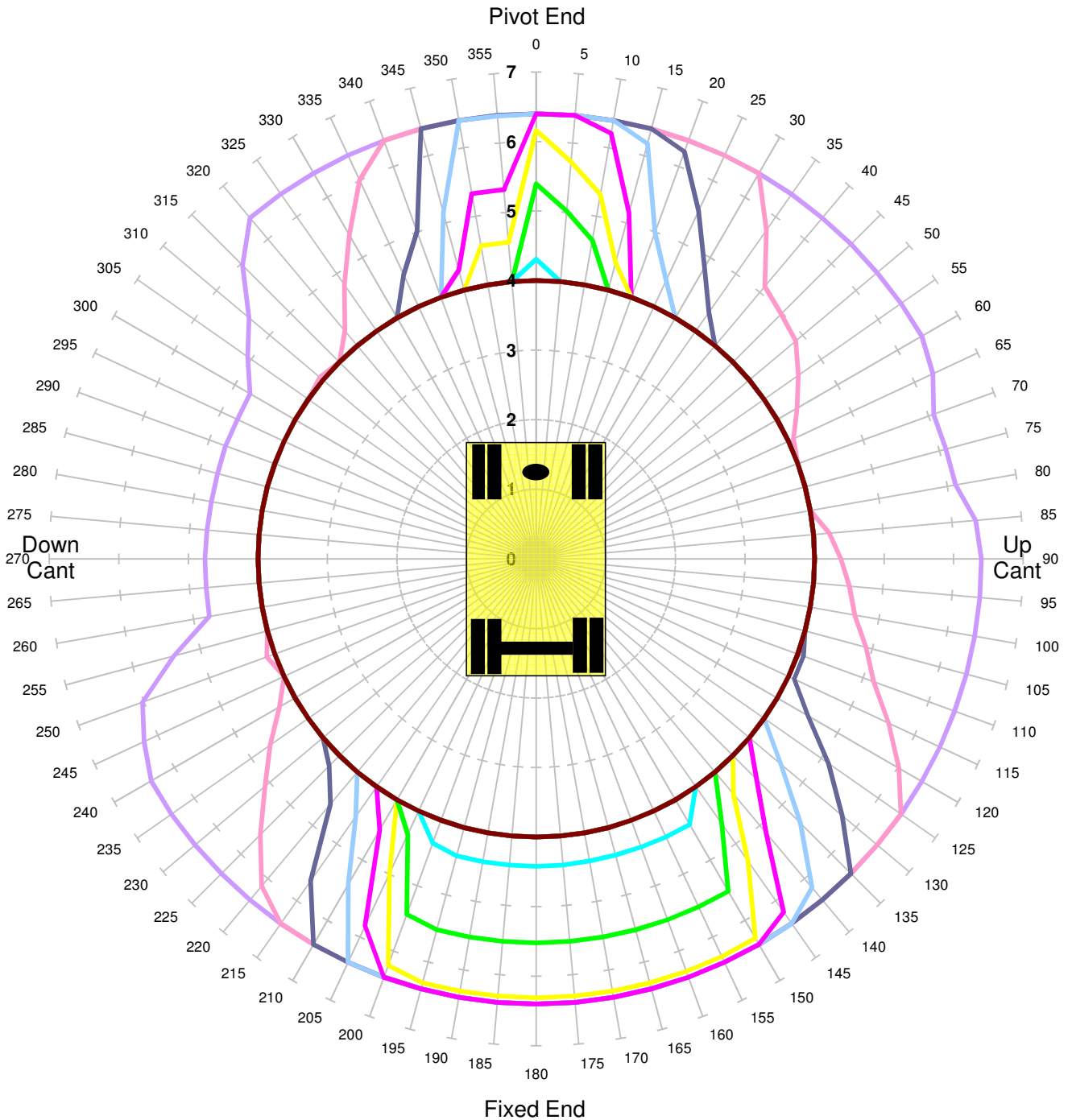

Units in Tonnes

— 1
 — 1.5
 — 2
 — 2.5
 — 3
 — 3.5
 — 4
 — 5
 — 6
 — 7
 — 8
 — 9
 — 10

MACHINE & MODEL:	CASE 988	REFERENCE:	CC587
SERIAL No:	231287 Plant Number 84	DATE OF CHART:	26-Jan-2016
EQUIPMENT:	4.30m + 2.10m	SAFETY FACTOR:	67.0%
COMMENT:			

CASE 988

**Max Capacity Contours of Radius(m) Plots 2.1m Dipper
Gradient 1 in -25 Heights 4m to 1m Lift BP**

Unlocked Rail Cant 150mm

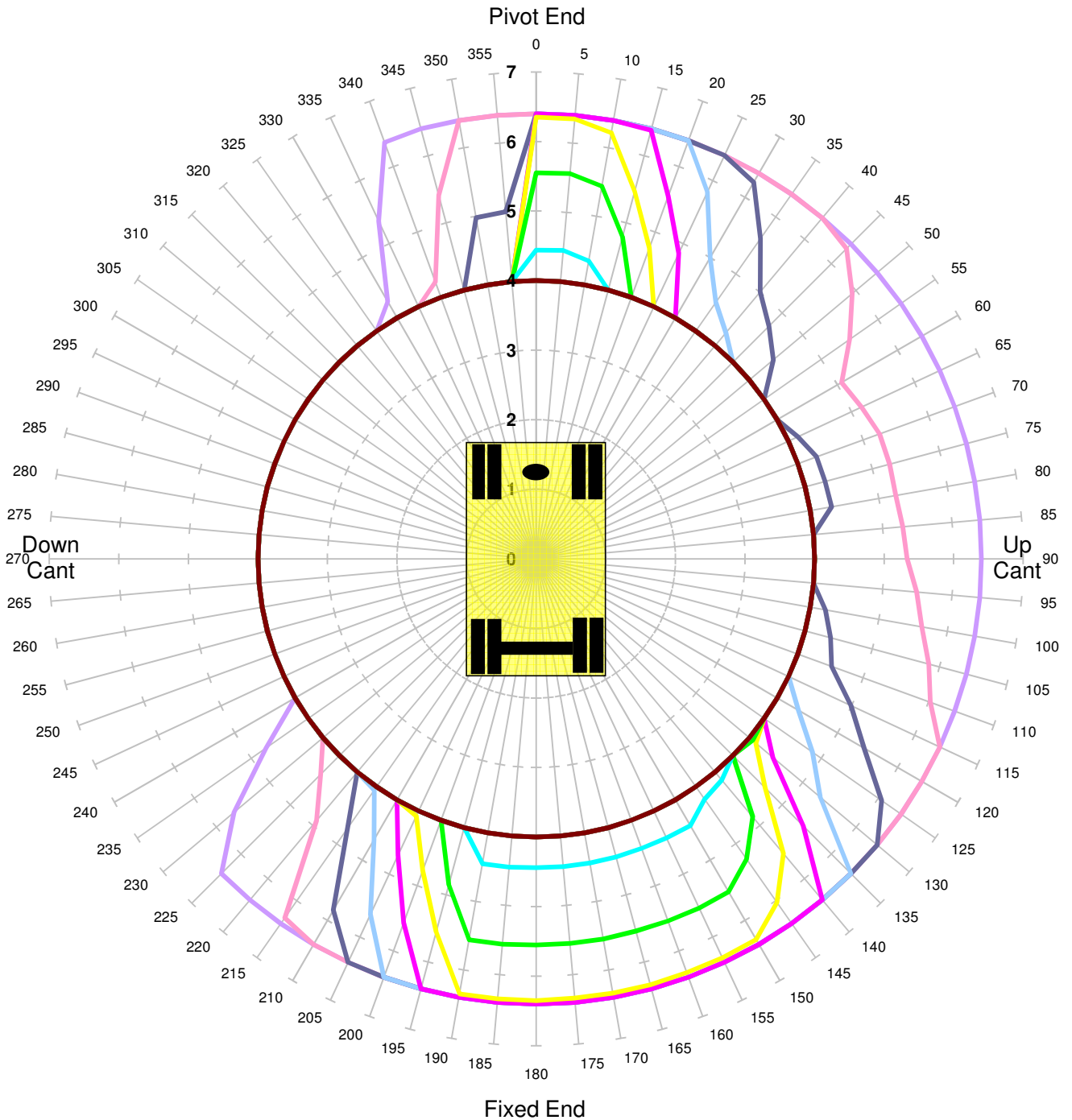

Units in Tonnes



MACHINE & MODEL:	CASE 988	REFERENCE:	CC587
SERIAL No:	231287 Plant Number 84	DATE OF CHART:	26-Jan-2016
EQUIPMENT:	4.30m + 2.10m	SAFETY FACTOR:	67.0%
COMMENT:			

CASE 988

**Max Capacity Contours of Radius(m) Plots 2.1m Dipper
Gradient 1 in -25 Heights 4m to 1m Lift BP
Locked Rail Cant -150mm**

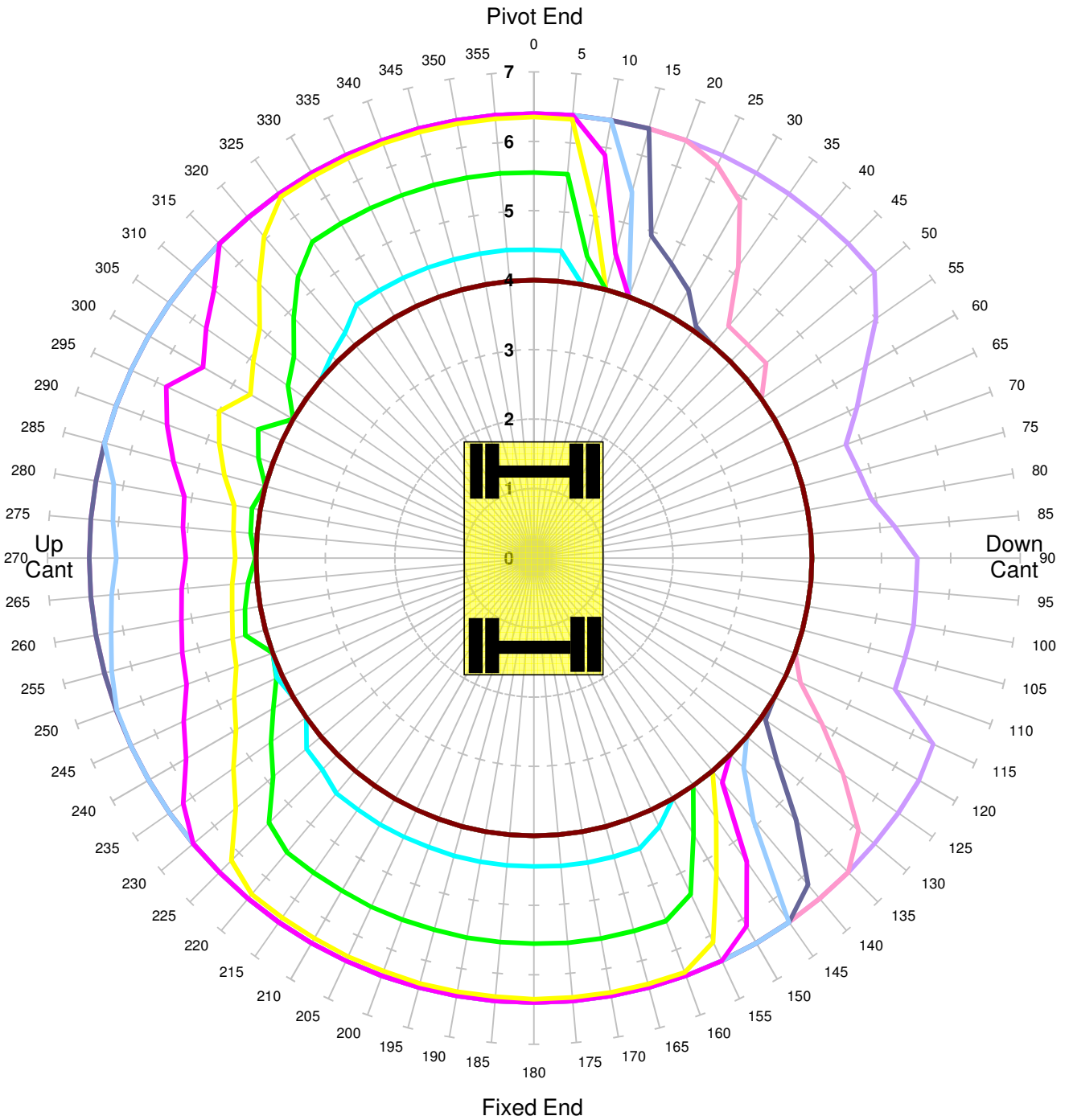

Units in Tonnes

- 1
- 1.5
- 2
- 2.5
- 3
- 3.5
- 4
- 5
- 6
- 7
- 8
- 9
- 10

MACHINE & MODEL:	CASE 988	REFERENCE:	CC587
SERIAL No:	231287 Plant Number 84	DATE OF CHART:	26-Jan-2016
EQUIPMENT:	4.30m + 2.10m	SAFETY FACTOR:	90.0%
COMMENT:			

CASE 988

**Max Capacity Contours of Radius(m) Plots 2.1m Dipper
Gradient 1 in -25 Heights 4m to 1m Lift BP**

Locked Rail Cant -50mm

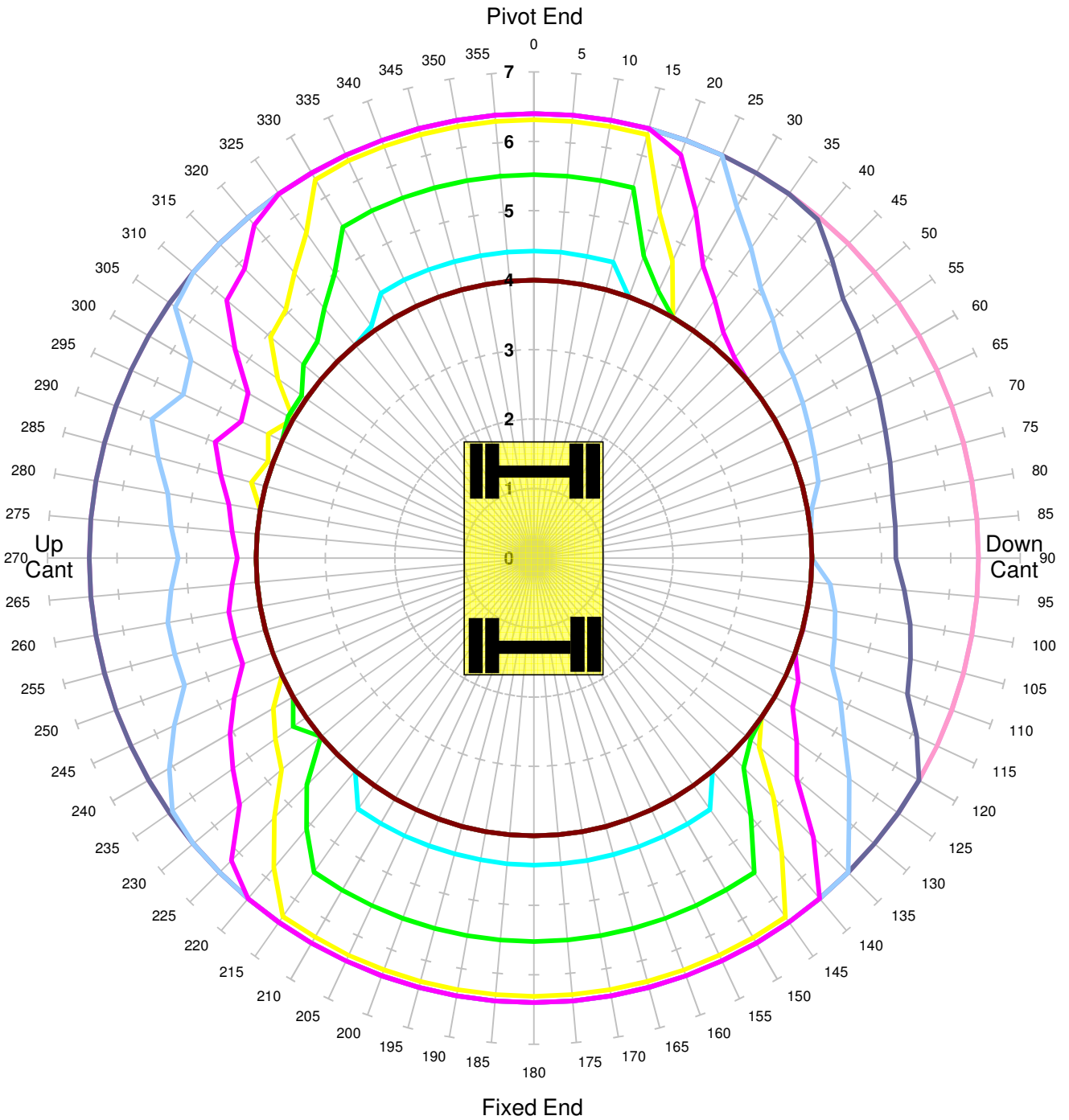

Units in Tonnes

- 1
- 1.5
- 2
- 2.5
- 3
- 3.5
- 4
- 5
- 6
- 7
- 8
- 9
- 10

MACHINE & MODEL:	CASE 988	REFERENCE:	CC587
SERIAL No:	231287 Plant Number 84	DATE OF CHART:	26-Jan-2016
EQUIPMENT:	4.30m + 2.10m	SAFETY FACTOR:	90.0%
COMMENT:			

CASE 988

**Max Capacity Contours of Radius(m) Plots 2.1m Dipper
Gradient 1 in -25 Heights 4m to 1m Lift BP**

Locked Rail Cant 50mm

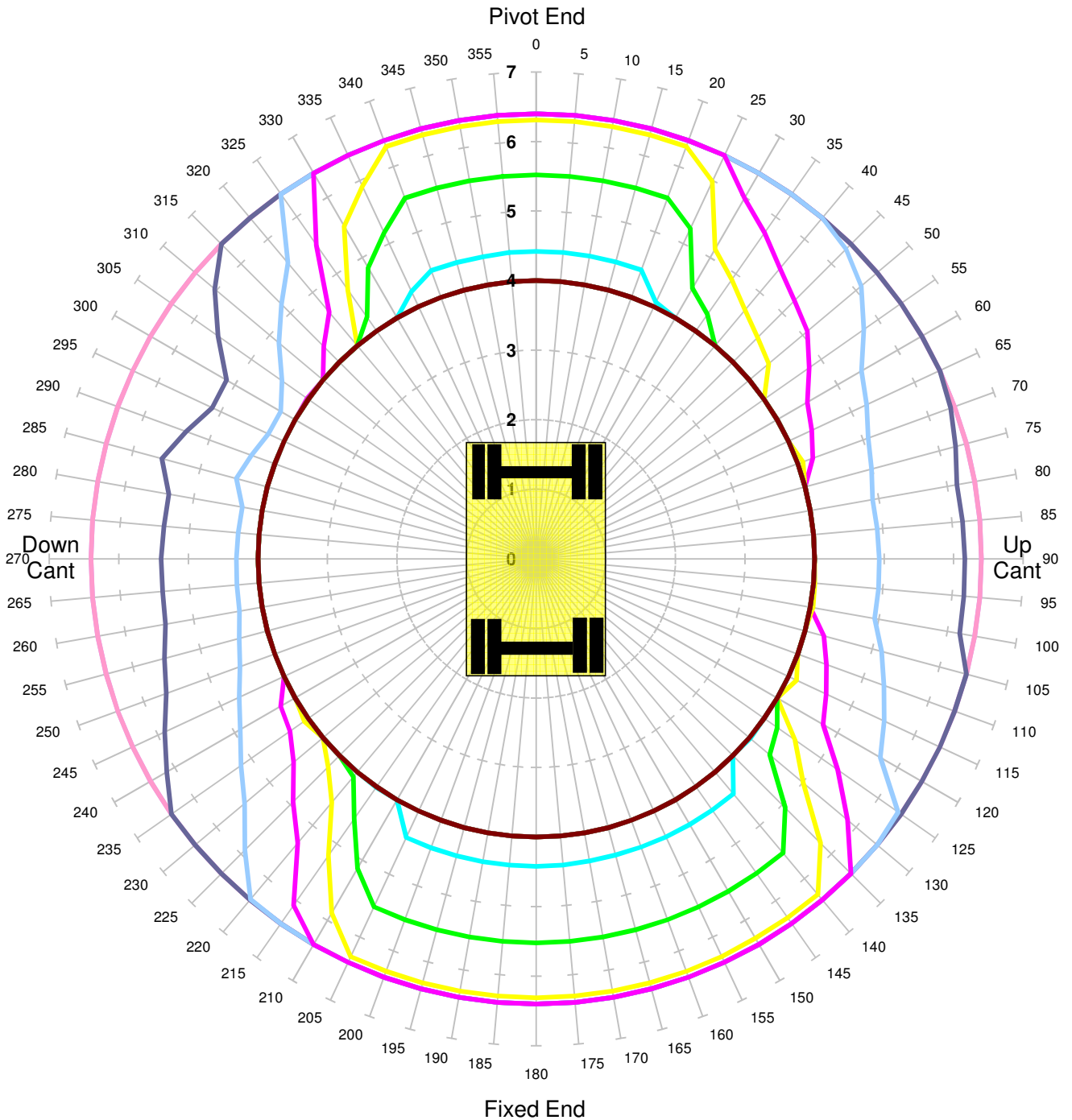

Units in Tonnes

— 1
 — 1.5
 — 2
 — 2.5
 — 3
 — 3.5
 — 4
 — 5
 — 6
 — 7
 — 8
 — 9
 — 10

MACHINE & MODEL:
SERIAL No:
EQUIPMENT:
COMMENT:

CASE 988
231287 Plant Number 84
4.30m + 2.10m

REFERENCE:
DATE OF CHART:
SAFETY FACTOR:

CC587
26-Jan-2016
90.0%

CASE 988

**Max Capacity Contours of Radius(m) Plots 2.1m Dipper
Gradient 1 in -25 Heights 4m to 1m Lift BP**

Locked Rail Cant 150mm

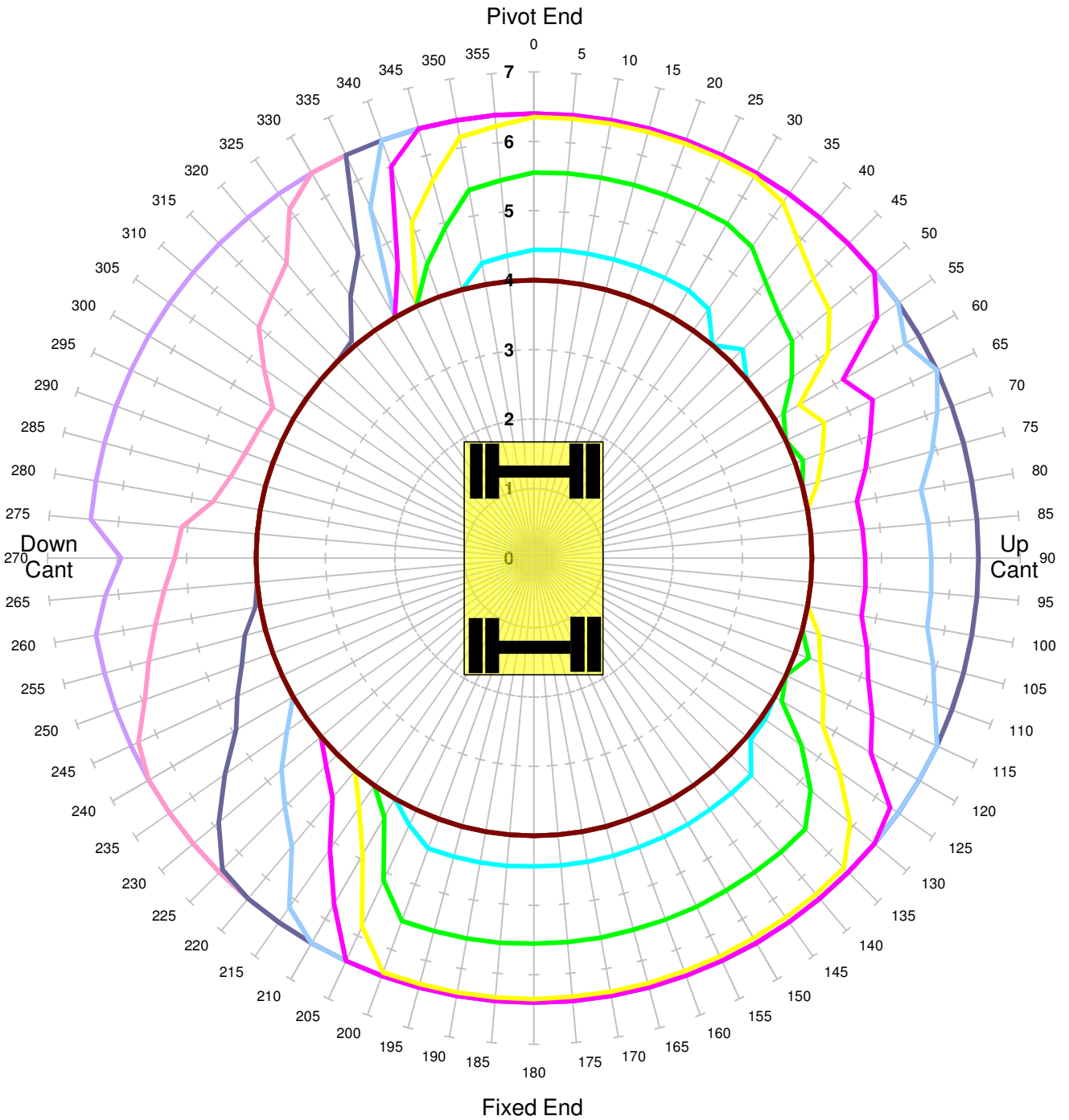

Units in Tonnes

- 1
 — 1.5
 — 2
 — 2.5
 — 3
 — 3.5
 — 4
 — 5
 — 6
 — 7
 — 8
 — 9
 — 10

MACHINE & MODEL:
SERIAL No:
EQUIPMENT:
COMMENT:

CASE 988
231287 Plant Number 84
4.30m + 2.10m

REFERENCE:
DATE OF CHART:
SAFETY FACTOR:

CC587
26-Jan-2016
90.0%

CASE 988
Max Capacity Contours of Radius(m) Plots 2.1m Dipper
Level Ground Heights 4m to 1m Lift BP
Unlocked Road

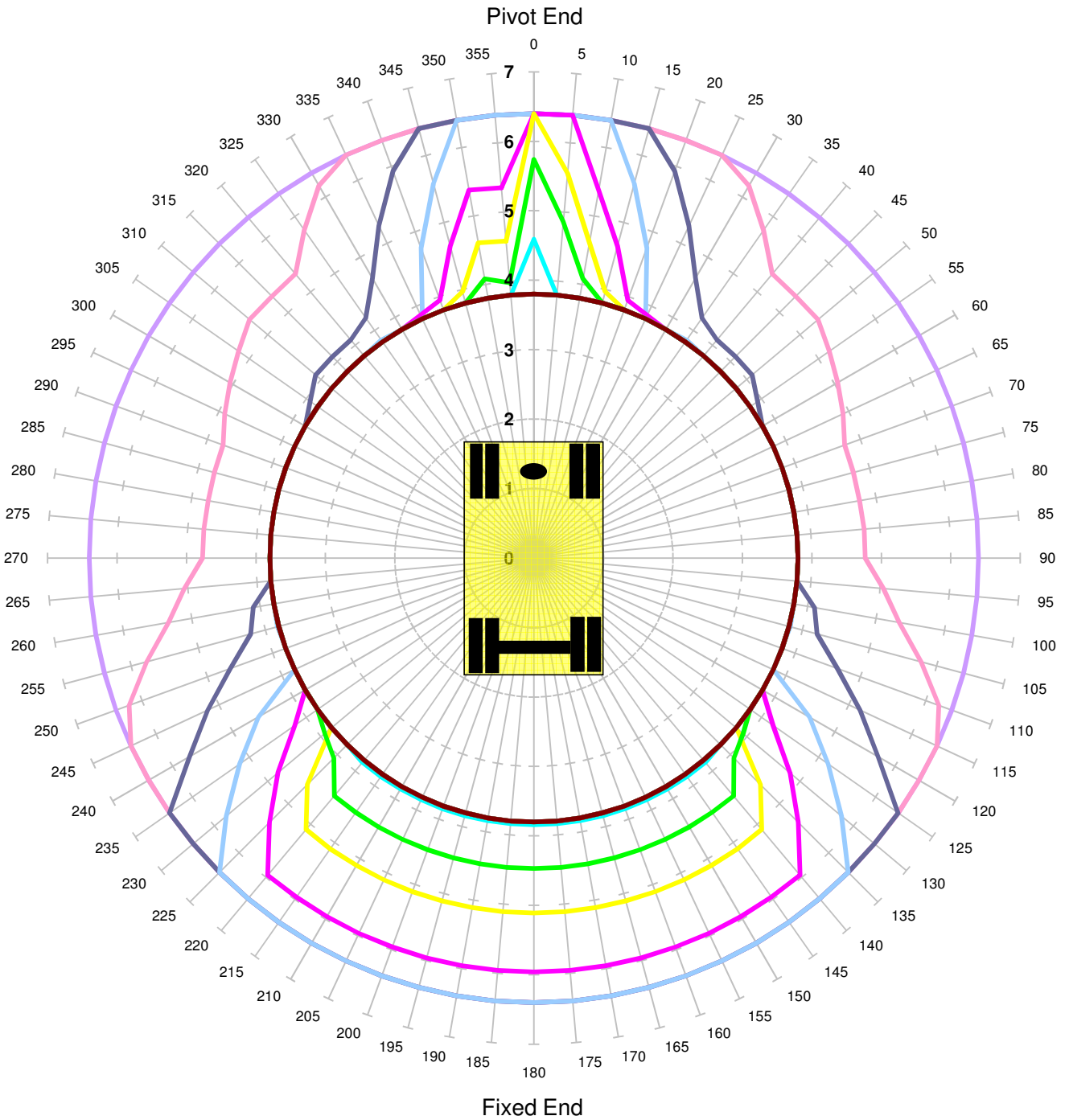

Units in Tonnes

- 1
- 1.5
- 2
- 2.5
- 3
- 3.5
- 4
- 5
- 6
- 7
- 8
- 9
- 10

MACHINE & MODEL: SERIAL No: EQUIPMENT: COMMENT:	CASE 988 231287 Plant Number 84 4.30m + 2.10m	REFERENCE: DATE OF CHART: SAFETY FACTOR:	CC587 26-Jan-2016 71.0%
--	---	---	-------------------------------

CASE 988
Max Capacity Contours of Radius(m) Plots 2.1m Dipper
Level Ground Heights 4m to 1m Lift BP
Locked Road

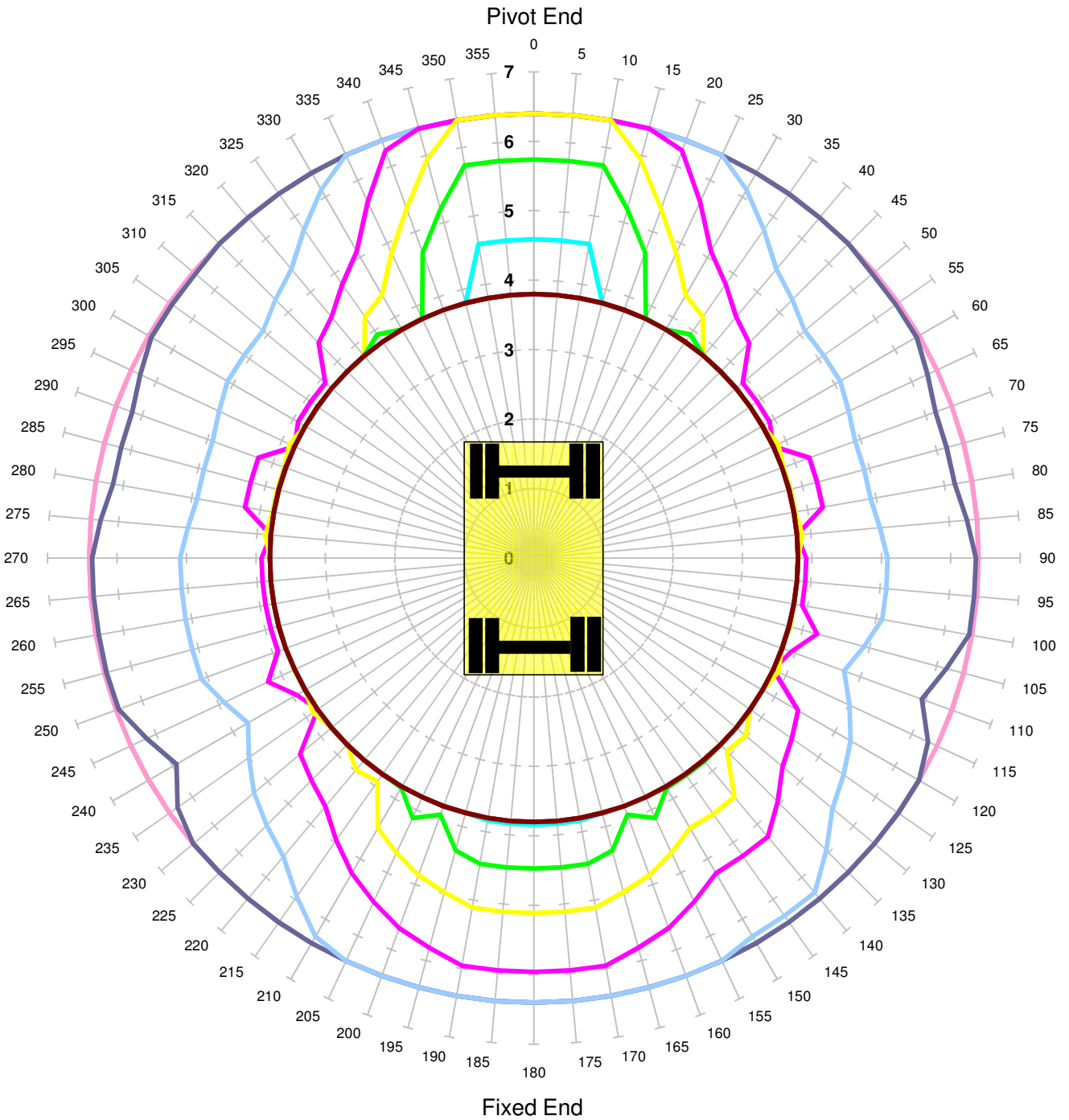

Units in Tonnes

- 1
- 1.5
- 2
- 2.5
- 3
- 3.5
- 4
- 5
- 6
- 7
- 8
- 9
- 10

MACHINE & MODEL: SERIAL No: EQUIPMENT: COMMENT:	CASE 988 231287 Plant Number 84 4.30m + 2.10m	REFERENCE: DATE OF CHART: SAFETY FACTOR:	CC587 26-Jan-2016 71.0%
--	---	---	-------------------------------

CASE 988

**Max Capacity Contours of Radius(m) Plots 2.1m Dipper
Gradient 1 in -25 Heights 4m to 1m Lift BP
Unlocked Rail Cant -150mm Tandem**

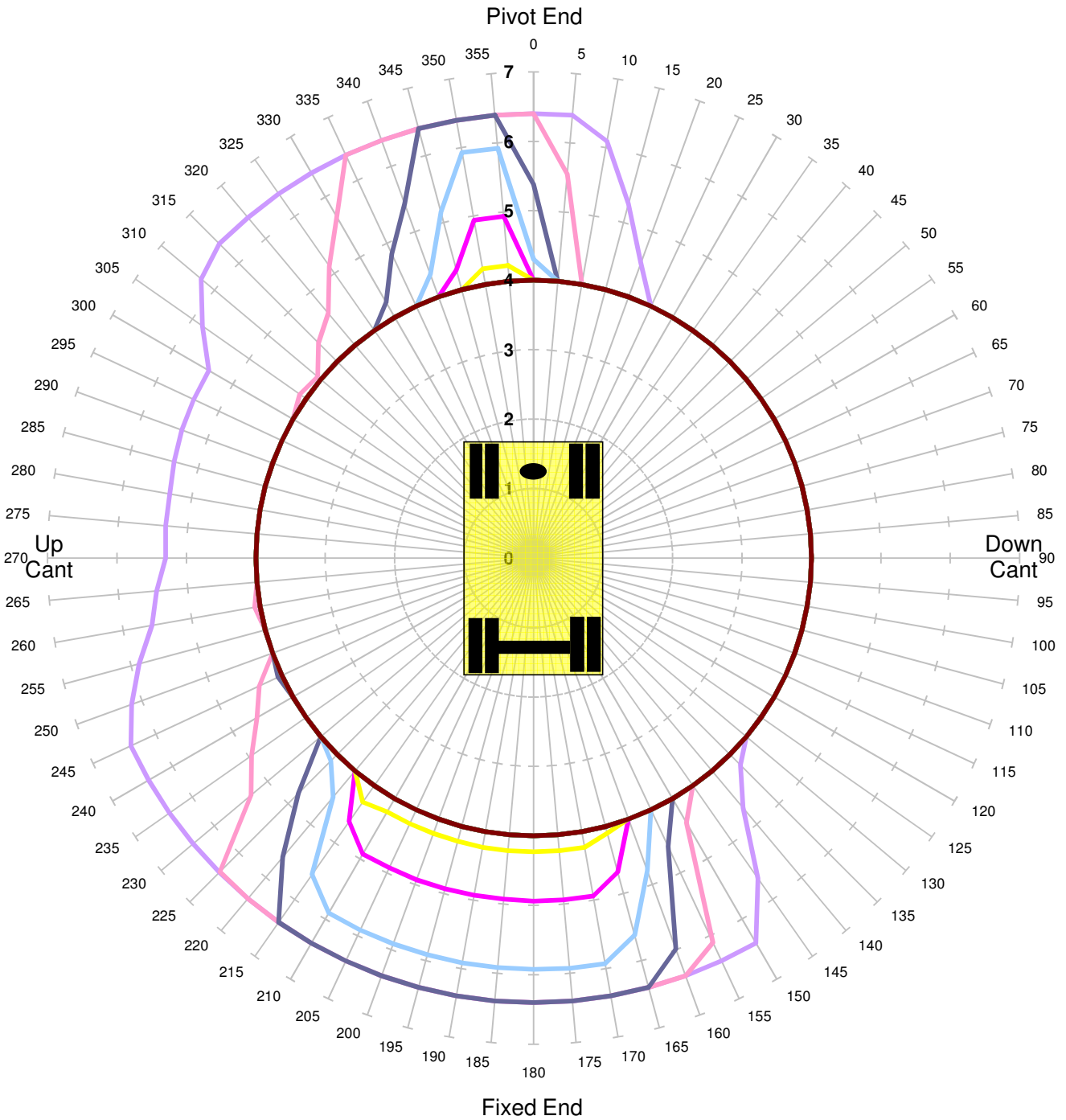

Units in Tonnes



MACHINE & MODEL:	CASE 988	REFERENCE:	CC587
SERIAL No:	231287 Plant Number 84	DATE OF CHART:	26-Jan-2016
EQUIPMENT:	4.30m + 2.10m	SAFETY FACTOR:	45.0%
COMMENT:			

CASE 988

**Max Capacity Contours of Radius(m) Plots 2.1m Dipper
Gradient 1 in -25 Heights 4m to 1m Lift BP
Unlocked Rail Cant -50mm Tandem**

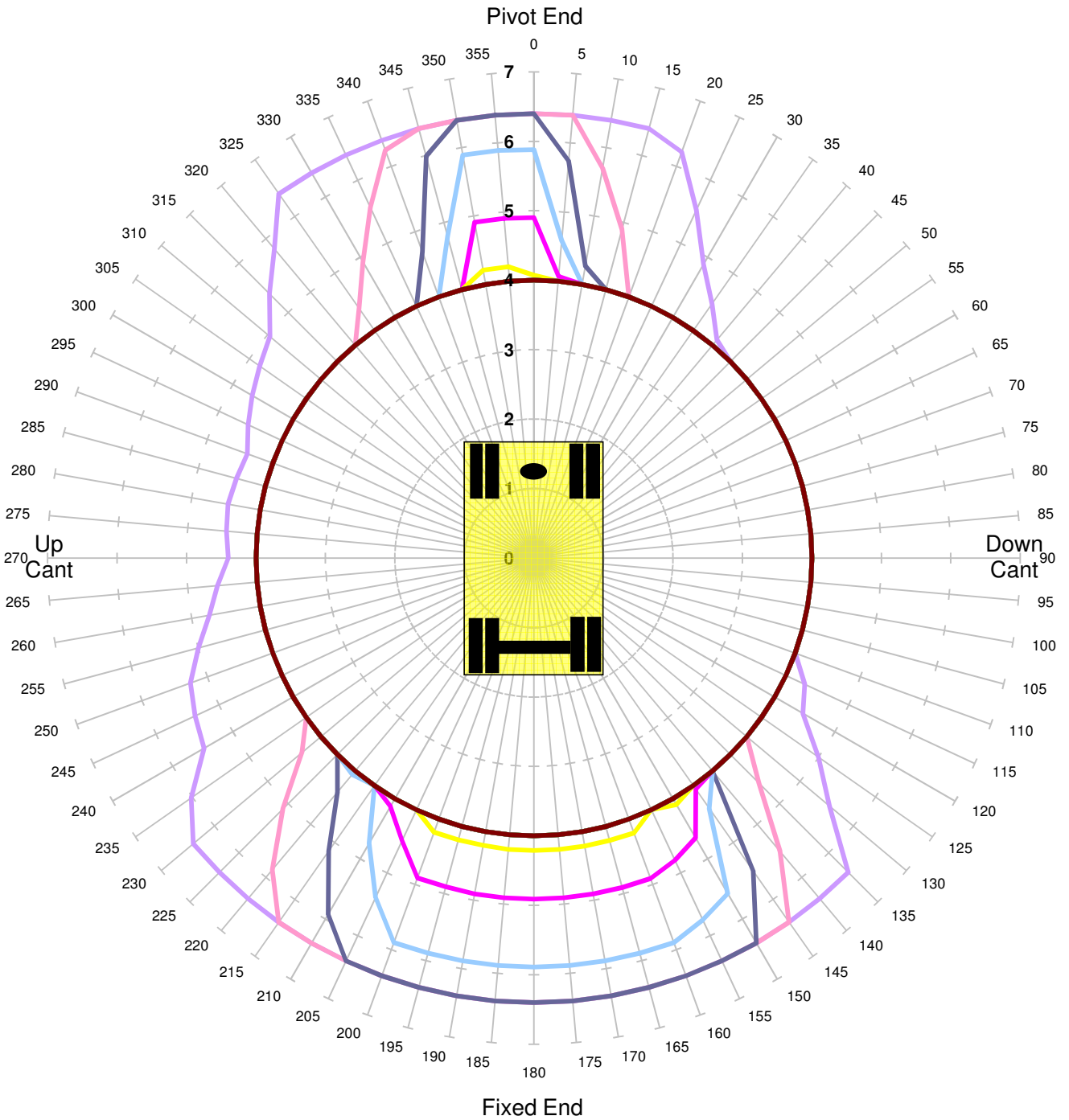

Units in Tonnes



MACHINE & MODEL: SERIAL No: EQUIPMENT: COMMENT:	CASE 988 231287 Plant Number 84 4.30m + 2.10m	REFERENCE: DATE OF CHART: SAFETY FACTOR:	CC587 26-Jan-2016 45.0%
--	---	---	-------------------------------

CASE 988

**Max Capacity Contours of Radius(m) Plots 2.1m Dipper
Gradient 1 in -25 Heights 4m to 1m Lift BP
Unlocked Rail Cant 50mm Tandem**

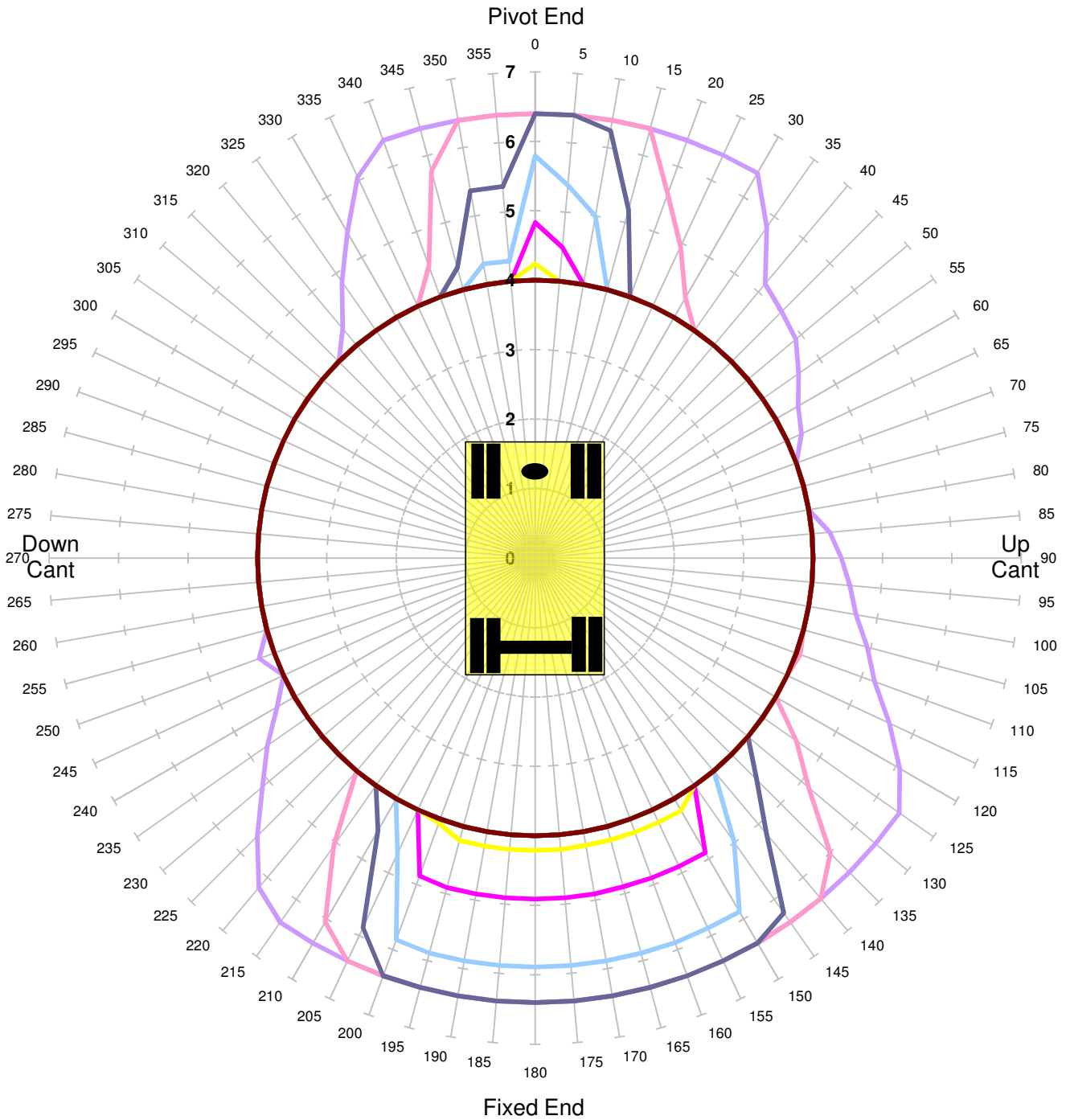

Units in Tonnes

— 1
 — 1.5
 — 2
 — 2.5
 — 3
 — 3.5
 — 4
 — 5
 — 6
 — 7
 — 8
 — 9
 — 10

MACHINE & MODEL: SERIAL No: EQUIPMENT: COMMENT:	CASE 988 231287 Plant Number 84 4.30m + 2.10m	REFERENCE: DATE OF CHART: SAFETY FACTOR:	CC587 26-Jan-2016 45.0%
--	---	---	-------------------------------

CASE 988

**Max Capacity Contours of Radius(m) Plots 2.1m Dipper
Gradient 1 in -25 Heights 4m to 1m Lift BP
Unlocked Rail Cant 150mm Tandem**

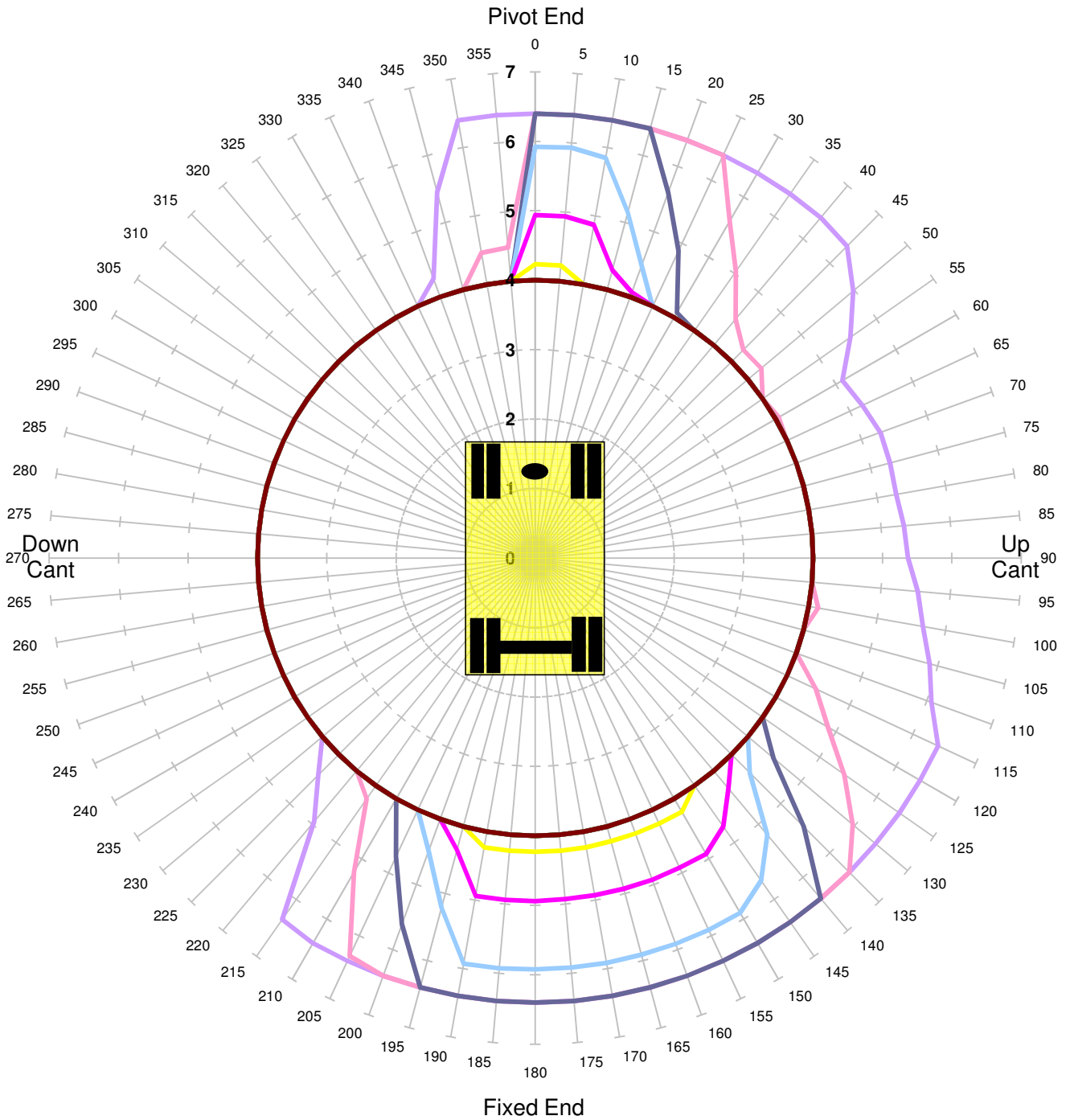

Units in Tonnes



MACHINE & MODEL:	CASE 988	REFERENCE:	CC587
SERIAL No:	231287 Plant Number 84	DATE OF CHART:	26-Jan-2016
EQUIPMENT:	4.30m + 2.10m	SAFETY FACTOR:	45.0%
COMMENT:			

CASE 988

**Max Capacity Contours of Radius(m) Plots 2.1m Dipper
Gradient 1 in -25 Heights 4m to 1m Lift BP
Locked Rail Cant -150mm Tandem**

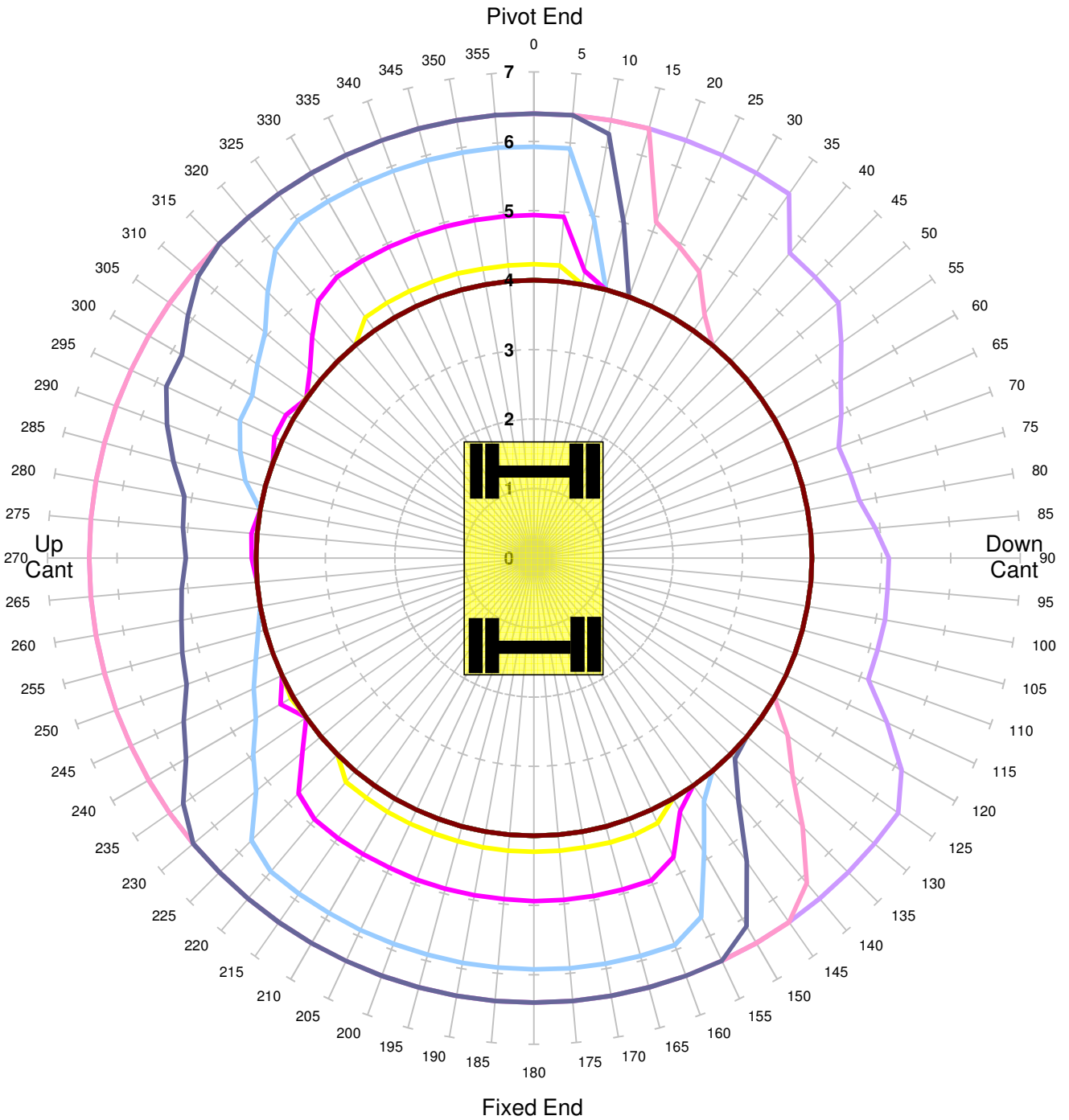

Units in Tonnes



MACHINE & MODEL:	CASE 988	REFERENCE:	CC587
SERIAL No:	231287 Plant Number 84	DATE OF CHART:	26-Jan-2016
EQUIPMENT:	4.30m + 2.10m	SAFETY FACTOR:	60.0%
COMMENT:			

CASE 988

**Max Capacity Contours of Radius(m) Plots 2.1m Dipper
Gradient 1 in -25 Heights 4m to 1m Lift BP
Locked Rail Cant -50mm Tandem**

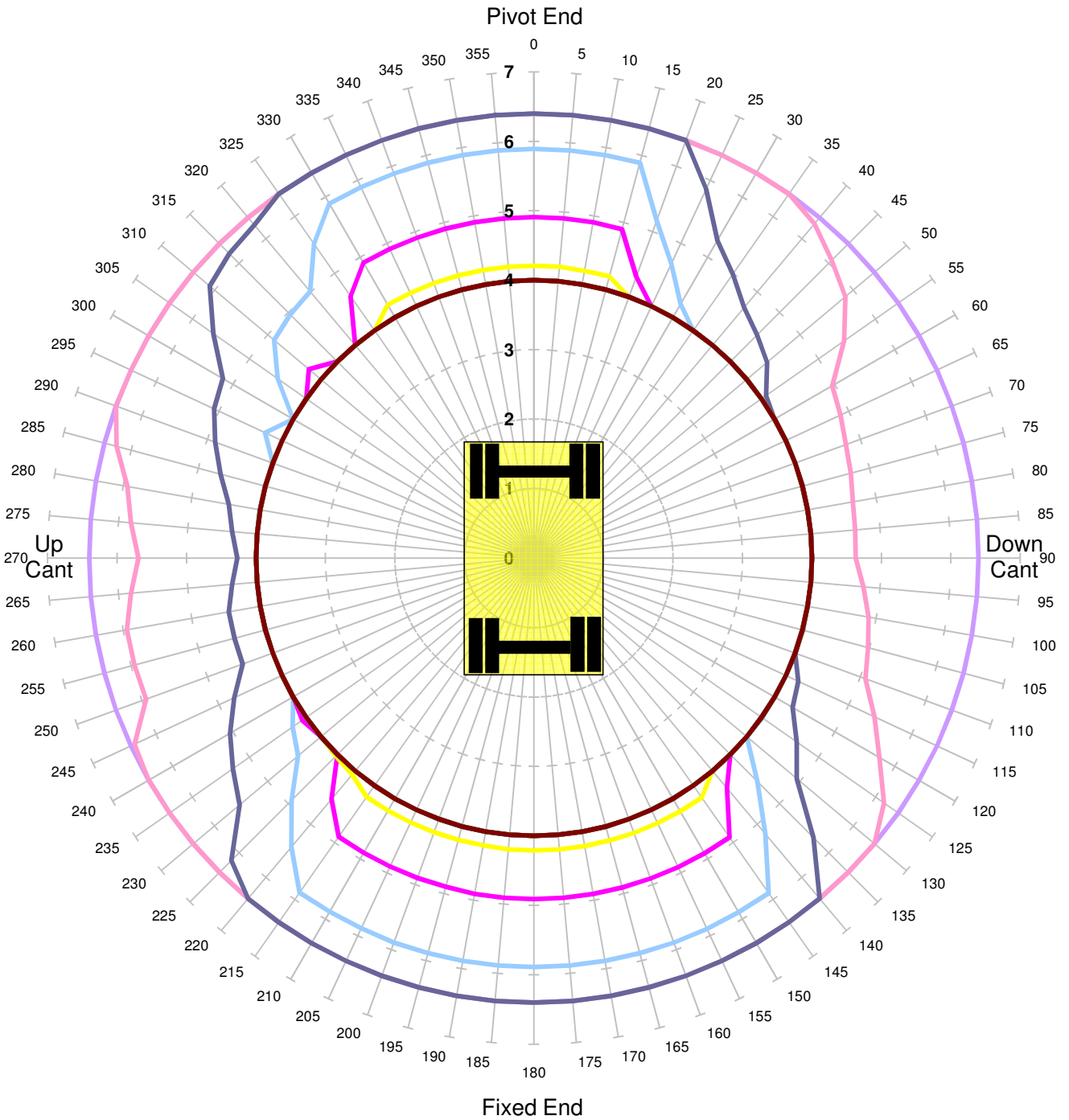

Units in Tonnes



MACHINE & MODEL:
SERIAL No:
EQUIPMENT:
COMMENT:

CASE 988
231287 Plant Number 84
4.30m + 2.10m

REFERENCE:
DATE OF CHART:
SAFETY FACTOR:

CC587
26-Jan-2016
60.0%

CASE 988

**Max Capacity Contours of Radius(m) Plots 2.1m Dipper
Gradient 1 in -25 Heights 4m to 1m Lift BP**

Locked Rail Cant 50mm Tandem

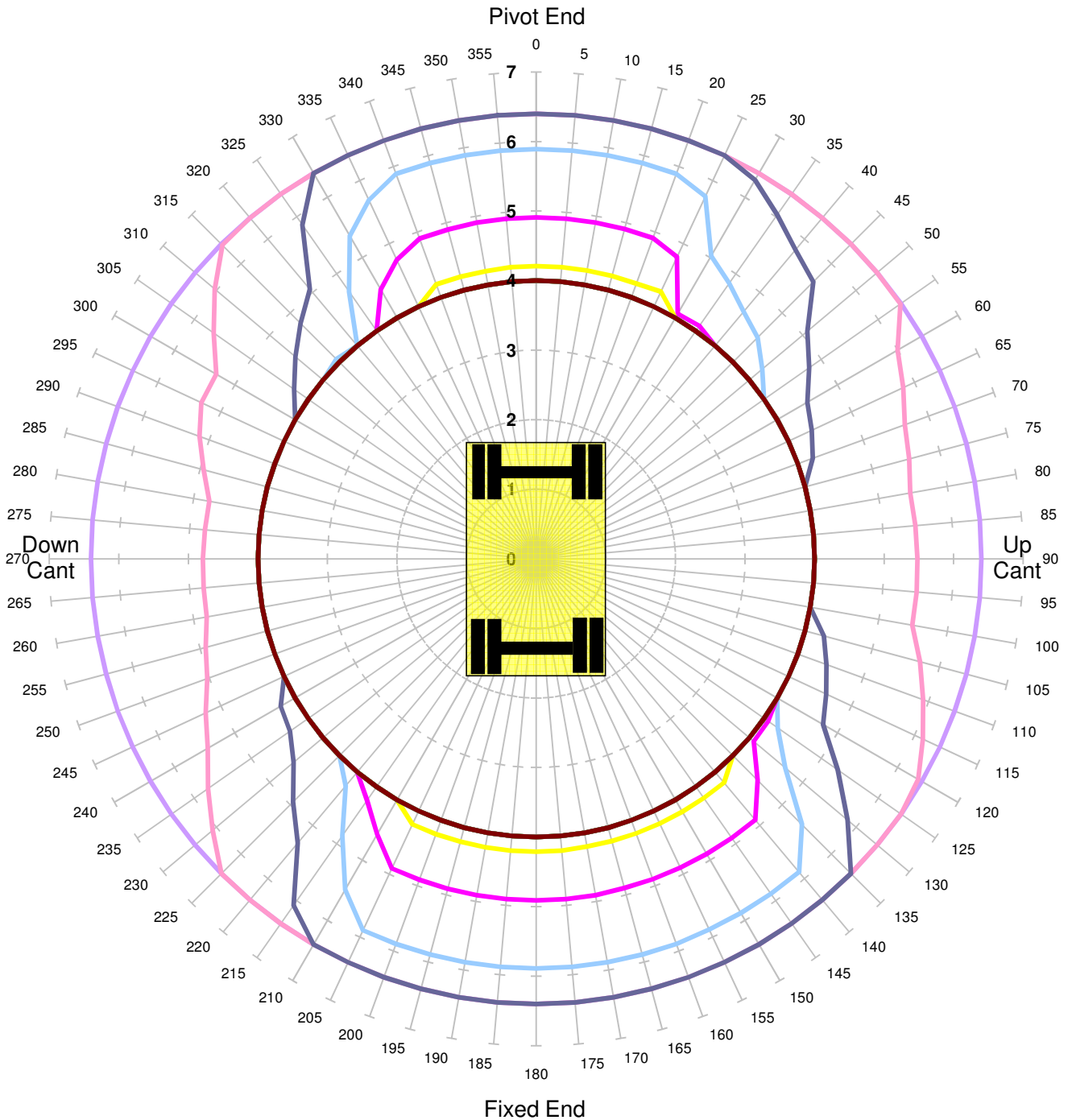

Units in Tonnes

— 1
 — 1.5
 — 2
 — 2.5
 — 3
 — 3.5
 — 4
 — 5
 — 6
 — 7
 — 8
 — 9
 — 10

MACHINE & MODEL:
SERIAL No:
EQUIPMENT:
COMMENT:

CASE 988
231287 Plant Number 84
4.30m + 2.10m

REFERENCE:
DATE OF CHART:
SAFETY FACTOR:

CC587
26-Jan-2016
60.0%

CASE 988

**Max Capacity Contours of Radius(m) Plots 2.1m Dipper
Gradient 1 in -25 Heights 4m to 1m Lift BP
Locked Rail Cant 150mm Tandem**

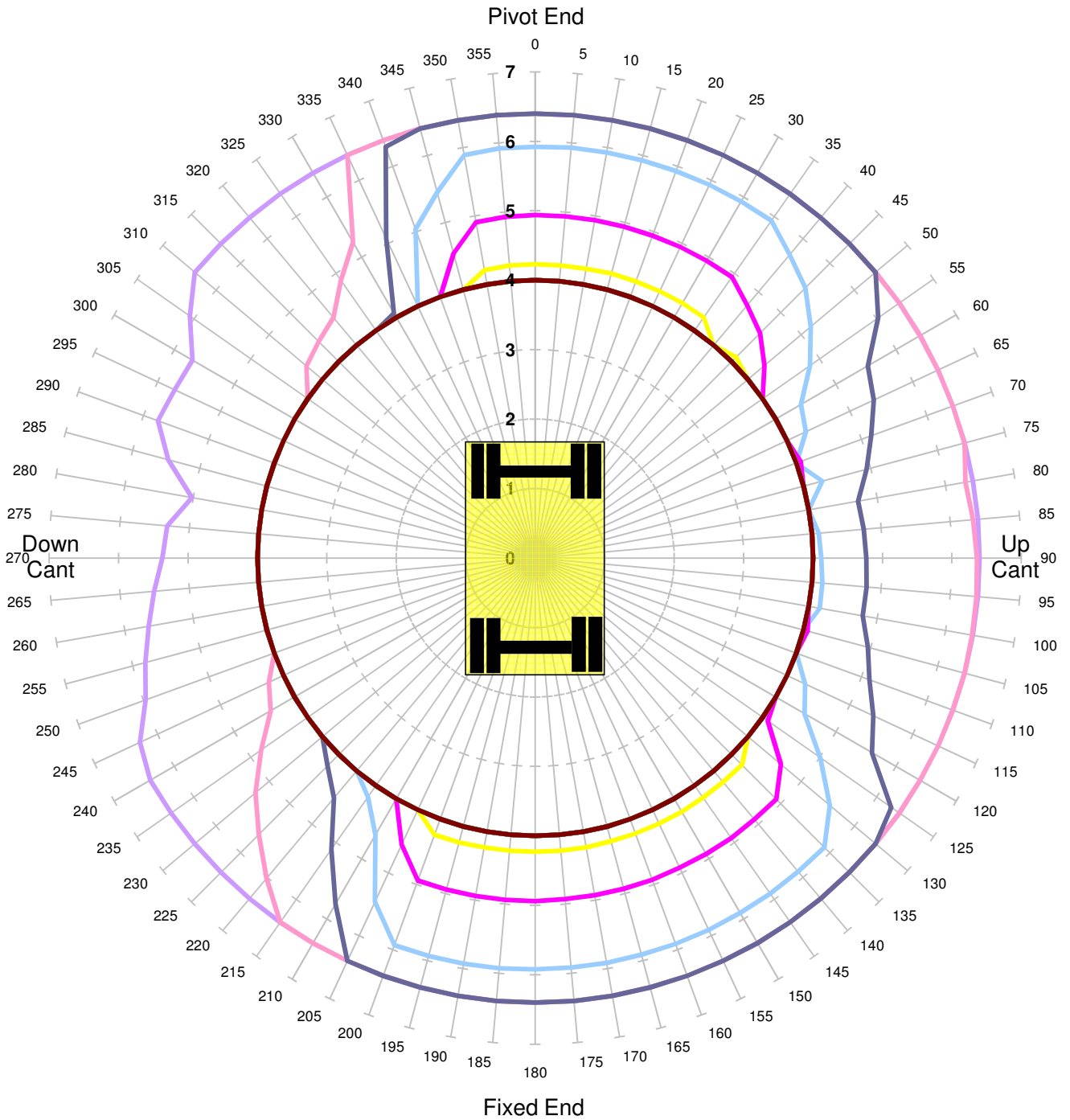

Units in Tonnes



MACHINE & MODEL:	CASE 988	REFERENCE:	CC587
SERIAL No:	231287 Plant Number 84	DATE OF CHART:	26-Jan-2016
EQUIPMENT:	4.30m + 2.10m	SAFETY FACTOR:	60.0%
COMMENT:			

CASE 988

Max Capacity Contours of Radius(m) Plots 2.1m Dipper Level Ground Heights 4m to 1m Lift BP Unlocked Road Tandem

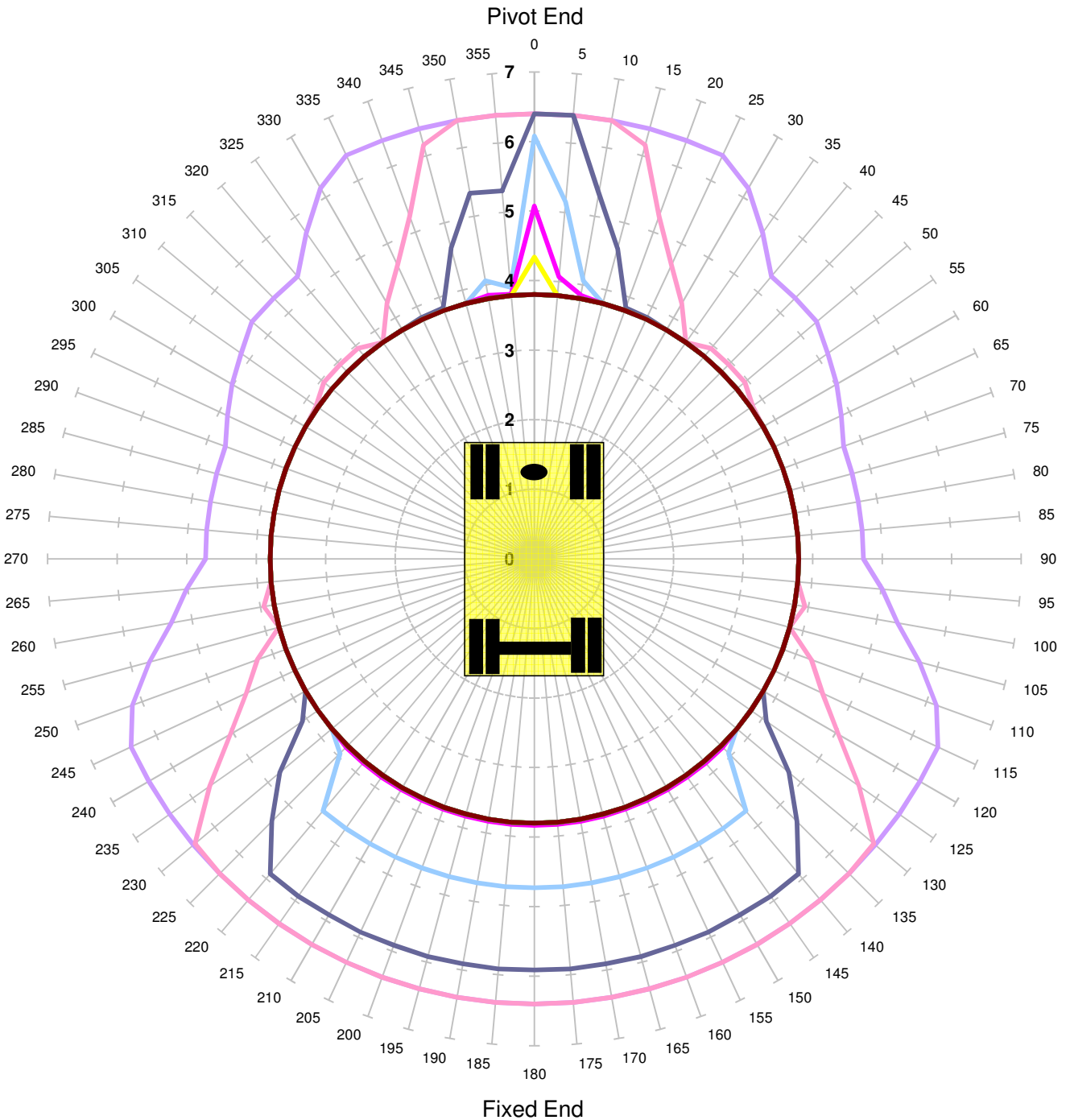

Units in Tonnes



MACHINE & MODEL: SERIAL No: EQUIPMENT: COMMENT:	CASE 988 231287 Plant Number 84 4.30m + 2.10m	REFERENCE: DATE OF CHART: SAFETY FACTOR:	CC587 26-Jan-2016 47.0%
--	---	---	-------------------------------

CASE 988

**Max Capacity Contours of Radius(m) Plots 2.1m Dipper
Level Ground Heights 4m to 1m Lift BP**

Locked Road Tandem

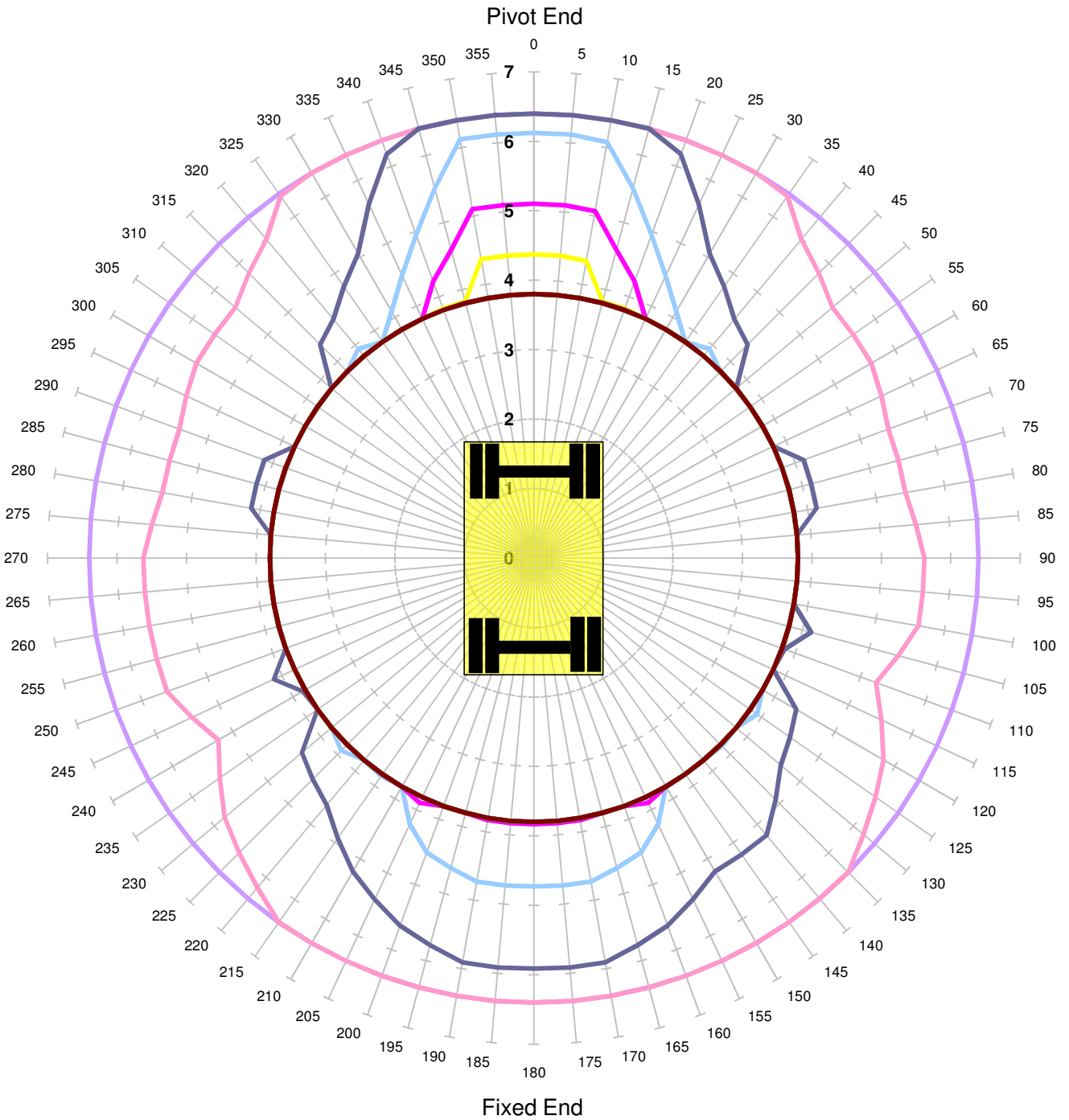

Units in Tonnes



MACHINE & MODEL: SERIAL No: EQUIPMENT: COMMENT:	CASE 988 231287 Plant Number 84 4.30m + 2.10m	REFERENCE: DATE OF CHART: SAFETY FACTOR:	CC587 26-Jan-2016 47.0%
--	---	---	-------------------------------